

# Diaphragm Pumps for Air, Gases and Vapours

INNOVATIVE  
TECHNOLOGY  
WORLDWIDE

**KNF**  
NEUBERGER



With fine control valve  
and vacuum gauge

## LABOPOINT® Mini Diaphragm Vacuum Pumps

### Technical features:

- 100% oil-free transfer
- Pure transfer, evacuation and compression
- Version for slightly aggressive or corrosive gases and vapours
- Maintenance-free
- Environmentally friendly
- High level of gas tightness.

### Series LABOPOINT® N 816.3 K\_.18 Pumps

Series N 816.3 diaphragm pumps are double-head, dry-running devices used in a wide range of laboratory applications. They transfer and pump down without contamination.

The heart of these very compact pumps is a KNF structured diaphragm. This patented diaphragm was stress-optimized using the Finite Elements method. As a result, we were able to make the pumps smaller while increasing the service life of the diaphragm.

The pumps are available in various versions differing in the materials which contact the media.

#### Material in contact with the pumped media

Type/OrderNo.	Pump head	Diaphragm	Valves
N 816.3 KN.18	PPS	EPDM	EPDM
N 816.3 KN.45.18	PPS	EPDM	EPDM
N 816.3 KT.18	PPS	PTFE-coated	FFPM
N 816.3 KT.45.18	PPS	PTFE-coated	FFPM

.45 = Pump with fine control valve and vacuum gauge

Technical data:	N 816.3 KN.18	N 816.3 KT.18
	N 816.3 KN.45.18	N 816.3 KT.45.18
Delivery (l/min) <sup>1)</sup>	16	16
Ultimate vacuum (mbar abs.)	15	20
Operating pressure (bar g)	0.5	0.5
Connectors for tube (mm)	ID 6	ID 6
Permissible gas and ambient temperature	+5...+40 °C	+5...+40 °C
Mains	230V/50Hz	230V/50Hz
Motor protection	IP 20	IP 20
Power P <sub>1</sub>	100 W	100 W
Operating current	0.6 A	0.6 A
Weight	3.95 kg	3.95 kg
Dimensions LxHxW (mm)	361/141/90	361/141/90
With thermal switch and power fuse		

Motors with other voltages and frequencies on request.

<sup>1)</sup> at atm. pressure

### Accessories and spare parts

Description	Details	Order No.
Silencer	G 1/8	000345
Hose connector	G 1/8, PVDF, AD 6 mm	014052
Fine control valve with vacuum gauge	suction side	056547
Spares kit	for N 816 KN	056315
Spares kit	for N 816 KT	056316

# Diaphragm Pumps for Air, Gases and Vapours

INNOVATIVE  
TECHNOLOGY  
WORLDWIDE



## Dimensions and performance characteristics

Pump down time for 10 l receiver

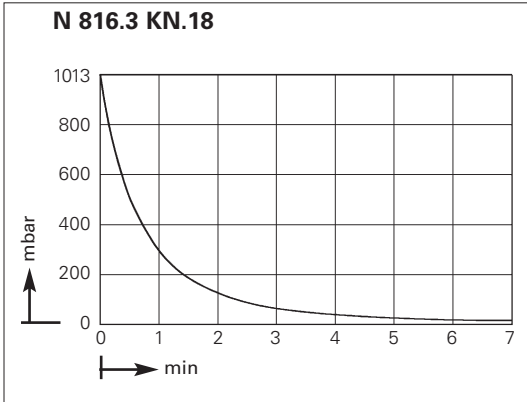

Performance characteristics

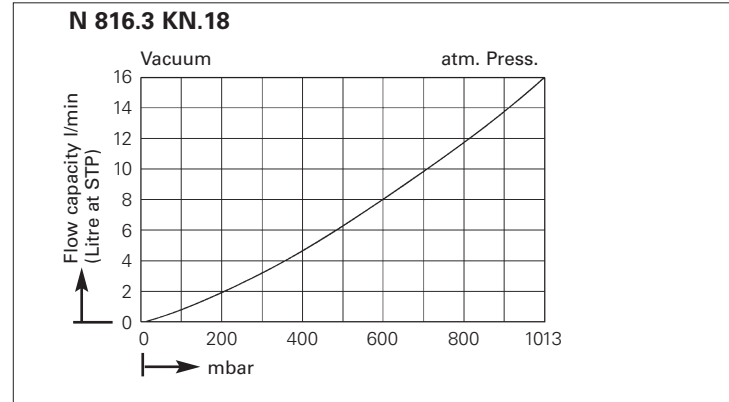

Pump down time for 10 l receiver

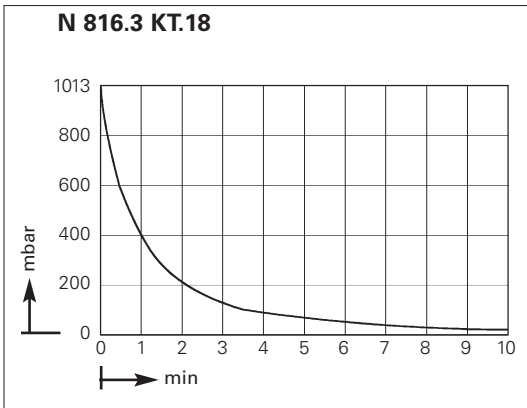

Performance characteristics

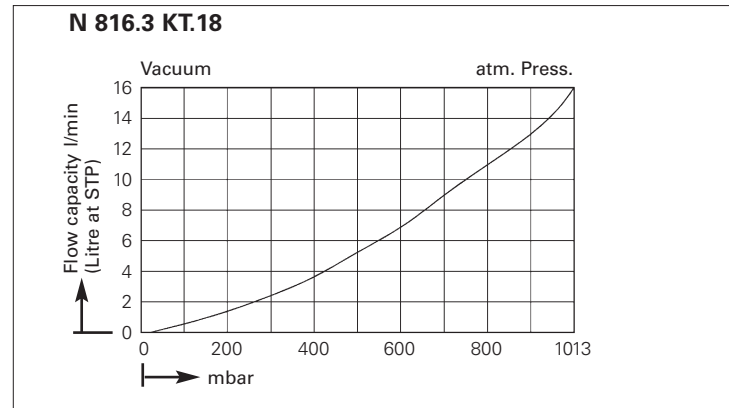

## Dimensions (mm)

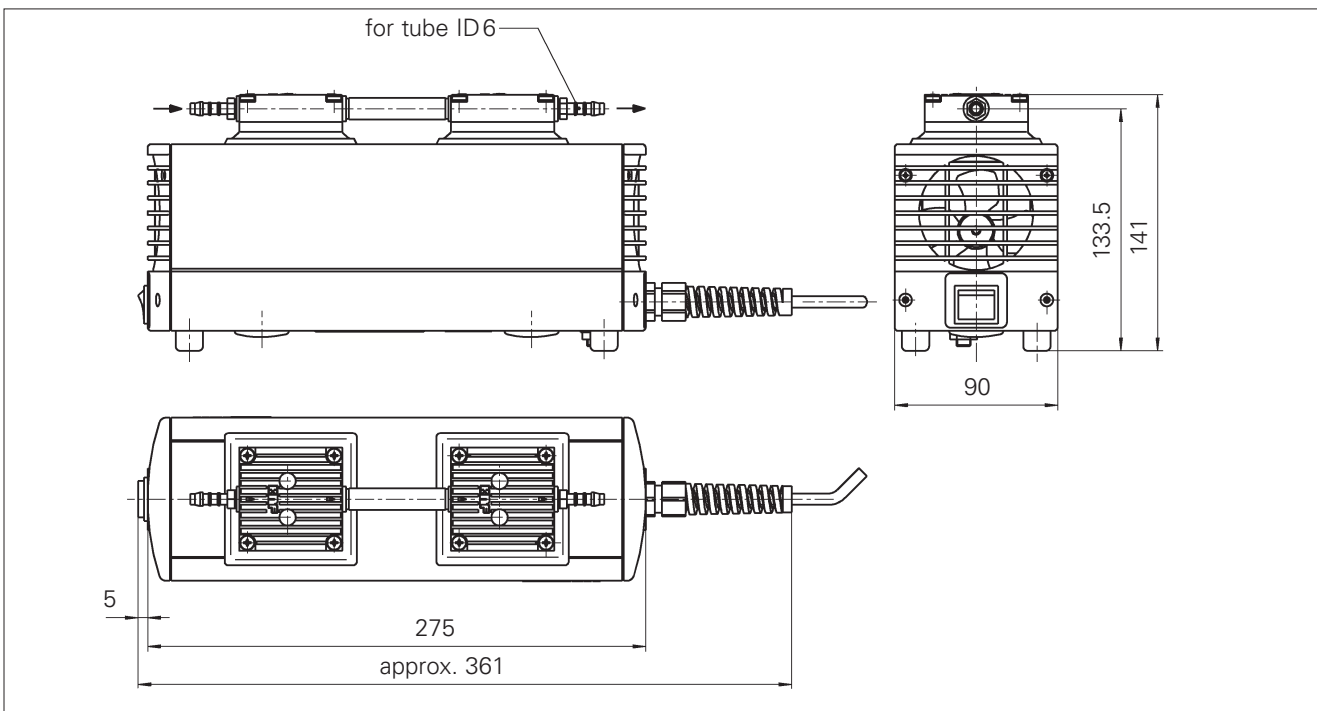



**Wolflabs**

# Wolf Laboratories Limited

[www.wolflabs.co.uk](http://www.wolflabs.co.uk)

Tel: 01759 301142

Fax: 01759 301143

[sales@wolflabs.co.uk](mailto:sales@wolflabs.co.uk)



**Use the above details to contact us if this literature doesn't answer all your questions.**

**Pricing on any accessories shown can be found by keying the part number into the search box on our website.**

The specifications listed in this brochure are subject to change by the manufacturer and therefore cannot be guaranteed to be correct. If there are aspects of the specification that must be guaranteed, please provide these to our sales team so that details can be confirmed.

